

VITIS & WINEMAKERS | New Zealand Edition

# PRODUCT CATALOGUE

[vitiswinemakers.com](http://vitiswinemakers.com)







<b>VITIS &amp; WINEMAKERS</b>	<b>5</b>
About Us Our Industry Out & About	
<b>1. Receival</b>	<b>10</b>
Crusher/Destemmers Grape Sorting Wine Presses Basket Presses Stalk Mulchers	
<b>2. Fermentation</b>	<b>26</b>
Fermentation Refrigeration	
<b>3. Maturation &amp; Storage</b>	<b>34</b>
Amphorae Tanks	
<b>4. Cooperage</b>	<b>40</b>
Tonnellerie Rousseau Barrel Washing	
<b>5. Filtration/Clarification</b>	<b>46</b>
Filters Separation/Clarification Flotation	
<b>6. Pumps</b>	<b>52</b>
<b>7. Distillation</b>	<b>56</b>
<b>8. Sparkling Wine</b>	<b>62</b>
<b>9. Bottling</b>	<b>66</b>
<b>10. Cider &amp; Perry</b>	<b>76</b>
<b>11. Accessories &amp; Fittings</b>	<b>80</b>

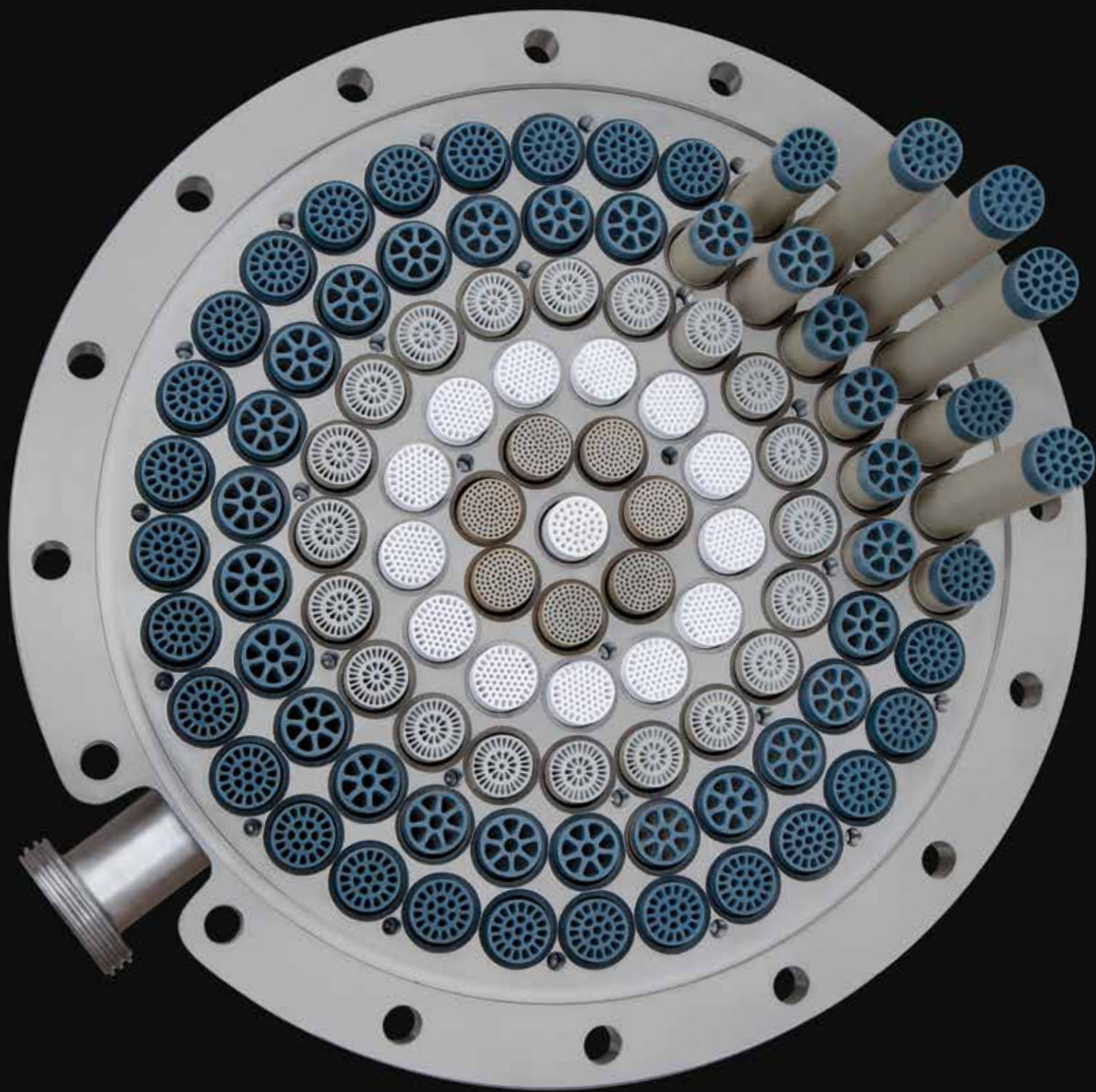

# About Us

**Might be a new name, but Vitis & Winemakers represents over 76 years of combined wine industry experience across Australia & New Zealand.**

We welcome a new era of growth brought to you by two industry stalwarts (previously named Australian & New Zealand Winemakers based in Australia and Vitis based in New Zealand) who've now merged forces to become a singular entity named Vitis & Winemakers. Aside from providing innovative & quality equipment solutions to commercial wineries and vineyards, we now boast one of the broadest inventories across the region as a result of the merger, including equipment and technology for grape receipt, fermentation, maturation and storage, oak products, filtration, pumps, distillation, cider, bottling, packaging and accessories and fittings. Our dedicated administration, sales, tech and engineering teams consisting of over 20 staff, are based in all key wine regions across Australia and New Zealand.

Vitis & Winemakers are the exclusive Australian and New Zealand agent for a number of Europe's foremost manufacturers. Specialist consultation is available for all equipment, complete winery design and total packaging solutions.

## ENGINEERING & TECHNICAL EXPERTISE

Vitis & Winemakers offers industry leading back-up and support, with personnel based across Australia and New Zealand. The team consists of highly skilled and experienced engineers, technicians, winemakers, distillers, advisors and product specialists. Additionally, we stock a wide range of spare parts locally.

## SALES TEAM

Our dedicated sales personnel are based in all key regions including Western Australia, South Australia, the east coast of Australia and New Zealand.

**For further information on our equipment and services, contact your Territory Manager or call our Head Office.**



**Vitis & Winemakers**

**NZ Office & Shop**  
24-26 Herbert St,  
Blenheim, New Zealand  
**Phone:** +64 3 577 8778  
**Head Office**  
96 Chifley Drive,  
Preston, VIC, 3072, Australia  
**Phone:** +61 3 9487 1160

**Web:** [www.vitiswinemakers.com](http://www.vitiswinemakers.com)  
**Email:** [info@vitiswinemakers.com](mailto:info@vitiswinemakers.com)

20+  
Staff



## Expertise

Five full time technicians  
to service on-site all  
year round



## Inhouse Engineering & Project Management



## Research & Development

Experts in wine,  
cider and spirits



Where we  
service



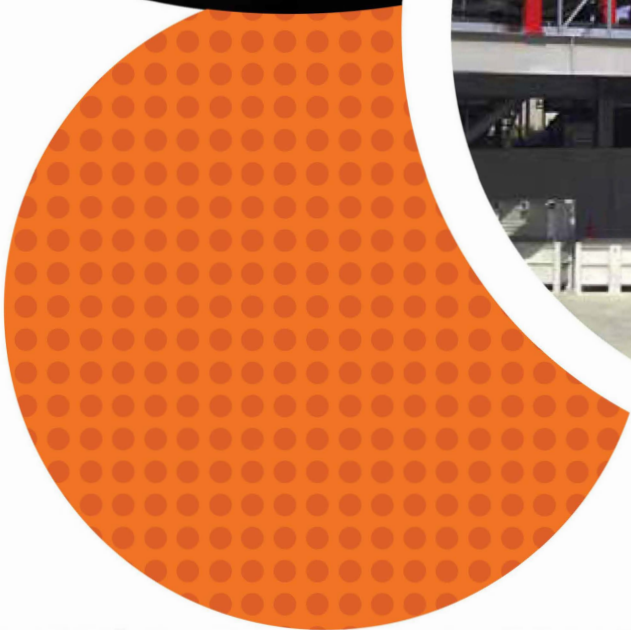

# Our Industry

## **Vitis & Winemakers is proud to present our latest showcase of winemaking technology and equipment.**

It is our aim to provide our winemaking industry with the most innovative, reliable and efficient products sourced directly from around the globe. All this is matched with a comprehensive technical and support team that works across the region to ensure that our clients' needs are met. We look forward to further contributing to the wine technology industry through events and trade shows, where we hope to reach the broadest audience we can.

We will continue to sponsor associations and unique competitions as we feel that in order for wine innovations and technology to thrive, we must participate in all conversations, across all facets of the wine industry. Further excursions to visit suppliers and manufacturers across the globe will enhance our wine industry locally and we look forward to bringing you more of their stories along the journey.



# Out & About

## Enological alchemists at your service!

We've been proudly touring Australia, New Zealand and the world to visit all the makers and producers that make our industry so incredible. Whether we are on the road to service or assist winemakers with their equipment needs, or just to visit our global manufacturers seeking the latest technologies and equipment, you can be sure that we are always out and about to ensure that Vitis & Winemakers is a truly productive and engaged part of this great industry of ours.

Request a site visit or service: [info@vitiswinemakers.com](mailto:info@vitiswinemakers.com)

Follow us: [!\[\]\(6605b201d6f14d9b3bcb8ab5f274d107\_img.jpg\)](#) [!\[\]\(f4056bb2e5acf0a782fb9d812dad489d\_img.jpg\)](#) [!\[\]\(23e633620764e54910cf7e601ab387fc\_img.jpg\)](#) [!\[\]\(a2795d87b2d80ef7779f5519aaa3b936\_img.jpg\)](#)







# 1. Receival

**CRUSHERS/  
DESTEMMERS  
GRAPE SORTING  
WINE PRESSES  
BASKET PRESSES  
STALK MULCHERS**

# Destemmers

**It is beautiful to see a totally dialed in destemmer in action. It is like a well-tuned piano, and the fruit coming from the destemmer is so clean it requires absolutely no sorting.**

The destemmer is key to production flow on the crush pad. Every piece of equipment prior to the destemmer (bin dumpers, sorting tables, elevators) must all be coordinated to deliver fruit smoothly. Similarly, all downstream functions are based on the throughput of the destemmer, and this is why every piece of the production puzzle must be in unison.

Your fruit, variety, characteristics and throughput requirements determine the equipment and/or control options the winemaker will need. Hands down one of the best friends a winemaker can have is speed control, but they also need to have plenty of adjustment to accommodate the fruit. You do not adjust the fruit to the machine but rather the machine to the fruit. Get every adjustment possible.

For the beginning winemaker you might not know all your needs, or they can change as your winery evolves. You may never be an expert, though experience after the first crush will help get you down the road. Remember, the key is getting absolutely every adjustment available.



# CRUSHERS & DESTEMMERS

A wide range from Della Toffola, Armbruster, CEP-Italy, SOCMA and TEM, with optional extension hoppers, allowing for direct picking bin feed.

## Armbruster ROTOVIB

The ARMBRUSTER destemmer/crusher is very gentle on the grapes - A specially shaped, slow-rotating pin shaft ensures optimum distribution of the grapes in the destemming cylinder, reduces suspended solids content, and increases output and performance. The Roto 10 and Roto 20 stand for top-quality design, workmanship and material and use of high-grade stainless steel or wear-free plastics guarantees long service life.

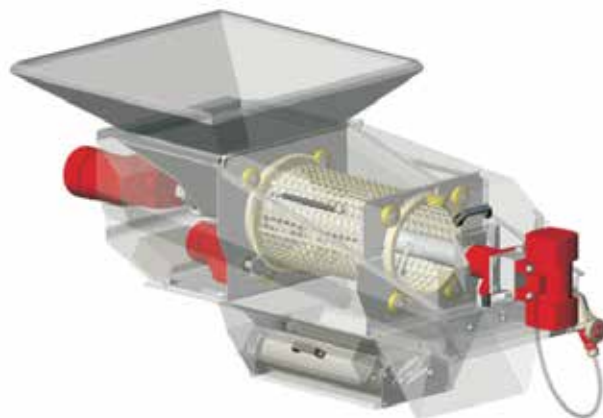

## The Madrina Destemmers

Madrina is the more innovative machine to work with selection lines and has an inverter for RPM regulation.

- Receiving hopper can be supplied with feeding screw or with direct skid to the holed basket
- It is equipped with telescopic legs to be fitted into selection lines
- Double holed stainless steel rotating basket, adjustable rubber paddles beater, motorized pressing rollers unit hinged to the hopper
- Rollers removable

## Precisa

The Precisa 50 Destemmer/Crushers are fitted with speed change drive. Standard beater with fixed rubber coated paddles or with adjustable rubber paddles. Standard basket in stainless steel with holes d.24mm or double holed 22/15mm. in stainless steel or white polyethylene. The rubber rollers are mobile and adjustable and can be tilted for washing. The outside pump to be connected to the machine can be of the type with rubber impeller, pistons, peristaltic or with single screw. In the version without tub, a pump with singlescrew, elliptic piston or peristaltic hopper is required.



- Includes hopper
- Must collection tub included
- Rubber coated paddles, rubber paddle available
- Adjustable Rubber rollers
- Two speed
- Plastic cage available
- Twin hole sized cages available
- The beater, basket and must collection tub are removable for easy cleaning.
- Single phase or 3-phase
- 4 - 5t/h, 5 - 7 t/h, 8 - 10 t/h, 12 - 15t/h

## Delta (Tem-Mori)



- Includes Hopper
- Fixed or removable basket
- Removable spindle
- Removable rollers
- Speed control available
- Must vat available
- Stainless Steel centrifugal must pump option
- Single Phase or 3-phase
- Plastic basket available
- Up to 3 t/h

## Euro Stainless Steel Destemmer/ Crusher With Motovariator

- Adjustable rollers with crush - non crush system
- Stainless steel cage with holes 24mm. diameter
- Speed variator
- Removable shaft with blades coated in food grade rubber that do not break the seeds

Available with Must collection tank with auger drive shaft attachment , and must collection tank for EURO 2/ZEUS 100/150 with screw and gear motor and electric start and stop.

Model	Production
Euro 1 with Inverter	4/6 Ton/h
Euro 2 with motovariator kw	7/10 Ton/h



## Beta

- Self-adjusting rubber rollers
- Completely in AISI 304 stainless steel
- Stainless steel cage with holes 24mm diameter
- Beater shaft with food grade rubber blades
- Must collection tank with feeder screws

Model	Production
Beta 40	3.5/5 ton/h

## Centrifugal Destemmer/Crusher

### WITH STAINLESS STEEL PUMP

- Beater shaft with food grade rubber blades
- Central machine opening
- Stainless steel cage with holes 24mm diameter
- Complete with centrifugal pump with attack

Model	Production
Beta 60	5/6 ton/h
Beta 90	8/9 ton/h

**Optional:** The Inverter variable speed drive for BETA 40 (pictured).



## Stand Alone Crusher Only

### STAINLESS STEEL WITH SELF-ADJUSTING RUBBER ROLLERS

Model	Production
Rull 70	6-7 ton/h
Rull 100	10 ton/h
Rull 150	15 ton/h
Rull 300	30 ton/h
Rull 500	50 ton/h

**Optional:** Loading hopper and electric panel upon request.

## Various Crusher Destemmers

- 1 - 1.5 tonne p/hr capacity
- 80kg hopper with electric powered screw auger
- Baked enamel or stainless steel finish
- Adjustable food grade rollers available in rubber or nylon
- Heat treated supports for rollers
- Light weight and easy to handle



## 'Delta' Crusher/Destemmer

- Built in must pump moves destemmed berries directly to the fermenter or press
- Available in 2, 5, 8 and 12 tonne p/hr models
- 5, 8 and 12 tonne p/hr models finished in stainless steel
- 2 tonne p/hr model available in baked enamel or stainless steel finish
- Lower auger feeds berries into the centrifugal must pump's impellor
- Body opens allowing greater access for easy cleaning

## Zeus Destemmer/Crusher (CEP)

### ENTIRELY IN STAINLESS STEEL

- Allows destemming and/or crushing any type of grape (including grapes harvested mechanically)
- Complete with large hopper to load with initial drainage system
- Variable speed drive by inverter and display showing the shaft speed beater



- Removable beater shaft and beaters coated with food-grade rubber
- Crusher with adjustable rubber rollers
- Springs which cushion the impact of the rollers in case of presence of foreign bodies
- Crush-non crush device

Model	Production
Zeus 100	8/10 ton/h
Zeus 150	10/15 ton/h
Zeus 300	20/30 ton/h
Zeus 600	40/55 ton/h
Zeus 800	60/70 ton/h
Zeus 1200	70/90 ton/h
Zeus 1300	100/120 ton/h

## Della Toffola NDC Destemmer/Crusher

- Available in 6 sizes, from 6-10 tonne p/hr (NDC 8) to 100-120 tonne p/hr (NDC 105)
- Full stainless steel construction including frame, perforated cage and beater shaft
- Adaptable for a range of applications including destemming and crushing, destemming only, partial destemming or crushing only
- Complete with electronic speed inverter to ensure full control Swing away fully adjustable crushing rollers in non-toxic rubber
- Beater shaft can be fitted with either non-toxic rubber pins or stainless steel blades
- Destemming cage holes reduce along length to ensure gentle separation of fruit from stalk. Cages also available in different diameters on request
- Complete with internal washing system, simple to dismantle for complete cleaning and inspection



## 'Gamma' Crusher/Destemmer

- Available in 4, 6, 8 and 10 tonne p/hr models
- Fully stainless steel with polished finish
- Stainless steel full rotating destemming drum, co-rotating with rubber destemming paddles
- Crusher with adjustable silicone rollers
- Roll away option to facilitate destem & crush or destem only
- Easy cleaning with removable destemming beaters, axle and drum



# GRAPE SORTING

Winemakers know that removing MOG will make a better wine. In the old days of winemaking, grape sorting was dumping buckets or bins of handpicked grapes onto a table where the harvest crew hand selected the good from the bad. Sorting table technology evolved from this, to a slow conveyor, and then to include vibrating conveyors, and conveyers to load the destemmer, which minimize or eliminated “surging” and “dumping” load variation into the destemmer, which is a major cause of MOG in that part of the process.

We offer a range of conveyors, vibrating tables, and destemmers that can be used individually or as a combined sorting line, from receipt through to destemmer.

## SORTING TABLES

- Built entirely of AISI 304 stainless steel with adjustable feet
- Grapes progress due to vibration
- Complete with grill pan draining and recovery must pull out
- Electrical panel with inverter for adjusting the vibration

### OPTIONAL:

Stainless steel hopper bins for channel separation grapes

## CONVEYORS

- Frame completely washable structure without the need to remove any parts, entirely in AISI 304 stainless steel
- Loading hopper measures at. 1000mm x 520mm
- Scraper for belt cleaning
- Must collection tank with Garolla 50 discharge
- Belt in food grade PVC
- Height adjustable with hydraulic cylinder and manual pump
- Stand with 2 fixed wheels and 2 steering wheels with brake





## SIX PROCESSES IN ONE CUBIC METER

- Removal of berries from the stems
- Distribution over the vibrating table
- Separation of juice and small debris
- Recovering of the free run juice
- Elimination of vegetative green matter
- Recovering of clean berries

## THE ANSWER TO YOUR GRAPE RECEIVING

- Simple
- A smaller size which allows better integration in the crush pad
- Easier to clean: reduced water use and labour

## MODULAR COMPONENTS

- Gentle destemmer
- Vibrating table to eliminate small MOG
- Viniclean to remove large MOG and separate berries
- Can be fitted to any existing receiving line

## Vibrating Hoppers

- Designed to gently move grapes from a tipping device to your sorting table so the stream of grapes is managed and consistent
- Built completely in stainless steel AISI 304
- Mounted on adjustable grid
- Liquid collection tank for must
- Inverter for electronic adjustment of the vibration
- Variable Flow from 3 - 25 ton/h



## Sorting Tables

- Advancement of grapes due to vibration.
- Built entirely of AISI 304 stainless steel
- mounted on adjustable feet
- 2 Vibrating motors
- Perforated surface at the front of the table to facilitate draining with juice collection tray
- Electric Panel with Start/Stop and
- Inverter for speed control of the vibrating motors
- Variable Flow from 3 - 25 ton/h



## Sorting Tables - Rollers

- Solid construction in AISI 304
- Two phase separation: berries and small plant parts in the first section and leaves and stalks in the next section
- Rollers are adjustable to suit different varieties
- The worktop height can be adjusted with the telescopic legs
- Any liquid is collected via a small tray with a Garolla 50 fitting
- Motor is 1.1Kw
- Worktop height is 1420mm
- Side height is 1480mm
- Electric panel with Start/Stop and variable speed control
- Maximum production 7 Ton/h



## Della Toffola Conveyors

Suitable for distributing and levelling grapes on the sorting table. The Conveyor lines comprise:

- Vibration hopper - complete with drainage and collection of free-flowing must
- Sorting table - available in various lengths, with non toxic rubber conveyor belt
- An adjustable - height elevator belt with hopper, complete with wheels, hydraulic pistons, manual pump and optional speed control
- A destemmer - crusher can be installed at the end of the line



## Grape & Marc Conveyors



- Supporting frame completely washable without removing any parts
- All stainless steel AISI 304
- Mounted on wheels
- Includes juice collection tray
- PVC food grade belt.
- Scraper for cleaning the belt
- Variable speed mechanical and electrical panel START and STOP
- Height adjustable from 1080mm - 1180mm
- Variable length 2500 - 3000 - 4000mm
- Variable width 600 - 800 - 1000mm

### Availability

---

300mm width x 2500mm length

---

300mm width x 3000mm length

---

500mm width x 3000mm length

---

500mm width x 4000mm length

---

Loading Hopper 1000 x 520mm

---



# WINE PRESSES

We've come a long way from the sack presses and manual foot pressings of the Egyptians. The sole function for a grape press is to separate the juice or wine from the skins - obviously enough - and the thoughtful application of technology by practical winemakers had led to vastly improved wine press performance. Solids are down, extraction pressures are lower than ever, speed is up, and wine/juice clarity is greatly improved. Flexible membranes and intelligent CIP systems ease the pain of cleaning.

For small winemakers with an eye on improving quality, and larger wineries looking to increase productivity without sacrificing quality (in fact, we can show you a quality improvement) the presses in this catalogue offer a great solution for every winery.

And, as with the increasing use of amphorae in winemaking, everything old is new again; you can see a great range of basket presses.

## Features & benefits of central membrane press technology

**WINEMAKERS AGREE** that the more rapid the grape juice is separated and drained from the polyphenol oxidase enzymes a lower concentration of browning fractions and oxidation occurs. It would hold then that a juice extraction design that more effectively efficiently ensures juice separation would be the press of choice for winemakers.

By virtue of the membrane press bag in any side bag press design taking up 50% of the tank surface area, little surface remains for drainage screens with side bag press designs by comparison to a design where by the whole tank surface is covered by drain screen. Take into account loading doors the typical drain screen surface available for side bag presses is only 22% - 24% of the press tank surface. When compared to the Della Toffola press design which provides 88% of its tank surface area with drain screens, it is clear why a Della Toffola press design is on many levels the superior pressing technology.

Central membrane press design by comparison to Side Bag press design:

- The whole inner press tank wall gets covered with drain screen surface;
- The axial feed can be positioned in the centre of the press tank (ref attached) to ensure more effective organic distribution of in-fed grapes occurring along the drain screen surface. With an axial infeed positioned at any one end of a tank press as per a side bag press design the pumped in grapes fall ultimately all at one end of that tank press. Positioning the axial feed at the end of any large tank press imposes the requirement to constantly rotate the tank using the flights within the press tank to distribute the grapes within the tank to any drain screen available. The larger the press the

more significant the problem. The process of grinding skins continuous along the flights we know increases solids generation significantly. The design of the Della Toffola press with the axial feed pipe positioned in the centre of the press tank is the suitable position to enable the in-fed grapes, in a static position (not requiring drum rotations) to distribute left and right screen areas. A significant reduction in suspended solids generation by comparison; and

- The juice drainage in central membrane presses occurs without the back pressure as occurs in side bag presses. The back pressure within side bag membrane presses has nowhere to go but to sheer through the skins and juice volume competing to push through the same drain channels out of the tank, very much through the very same path the juice must travel. This is not the case for central membrane presses where by the path of least resistance for the back pressure/ air gets vented in the opposite direction of the draining juice to atmosphere out the north-facing axis. The concentrations of dissolved oxygen mixing with the concentrations of polyphenols is dramatically reduced for Della Toffola press designs. Studies performed by the University of Adelaide highlighted this dynamic, resulting in lower concentrations of browning fractions for Della Toffola extracted juice compared to side bag juice extraction.



The popularity of vineyard destemming is changing a lot of the thinking surrounding front-end grape receive. How suspended solids and 'lees' are generated and how best they are managed has dominated the winemaking narrative in these last years. The investment into flotation and importantly the costs associated with high solids cross flow to process juice lees has had the most striking impact as to focusing on how juice solids can be reduced. Investing in a press technology that reduces the solids loading for down-stream processes is what is influencing the decision to invest in Della Toffola press technology.

#### THE FACTS:

- Della Toffola tank presses can be loaded at faster rates of 100-130m<sup>3</sup>/hr. They can simultaneously drain at rates faster than 100m<sup>3</sup>/hr and can do so in a static position with the door hatch closed. A 240hl press can have loaded some 75tn, a 100m<sup>3</sup>/hr pump would load and drain a 240hl Della Toffola press in 3/4hr. The performance of side bag presses by comparison accept 50-55tns of grapes and require 1.30hrs on average to load;
- The load volumes of a Della Toffola 480hl press are 110tn to 120tns and can be loaded with a 130m<sup>3</sup>/hr pump in under an hour. Press cycles for Della Toffola presses are typically 90 to 100 minutes. The same cycle time is required for the 240hl press as for a 480hl press. The vertical channel drain design coupled with the fact that with a central membrane the distance of extension and retraction of the membrane press bag being half that of side bags the performance no matter how more longer or wider the press tank may be the press cycle remains linear. This is certainly not the case for side bag presses. The larger they get the less efficient and less effective the drain and separation becomes;
- As Della Toffola presses can have positioned two marc doors on each axis the marc removal time is only 15 minutes. The time required to remove the same volumes from side bag presses is significantly more and becomes more cumbersome as the presses increase in dimension and volume; and
- Cleaning time required for grape to grape processing is approximately 15 minutes. Hot water and caustic can be injected into the tank press to effect any more intensive CIP regimes or to accelerate a more intensive clean program. The ability to install three, even four doors, for a central membrane press enables the most effective ease of access of any tank press design. If internal access to tank presses are a priority concern, then the Della Toffola design better mitigates the issues of confined work space compared to other presses.

The total complete turn-around press cycle time for a Della Toffola press is three hours, with one of our large clients processing per day with two 240hl Della Toffola presses 700-750 tonnes per day. It is technically possible to perform six cycles in a 24 hour period. Thus not only do central presses extract a lower suspended solid extract, with lower polyphenol browning fractions, but each tank press load can have added up to 40% additional grape volume by comparison and will process in a turn-around time nearly twice as fast as any side bag press.

Do the screens need to be taken off? The resoundingly feedback by our customers is that they only remove the screens once a year post vintage. Some of our most experienced customers have concluded that they do not need to remove the screens at all. Where increasing Occupational Health and Safety legislation is encroaching on the ability of technicians being able to access confined spaces, the proven design of the Della Toffola vertical screen design not requiring any need to be removed has been welcomed. As already outlined, the mere fact that our current advised CIP times are only 15 minutes to effect what most wineries claim is best practice, any more intensive regimes required can be easily accommodated.

**NB: Given per day the performance of any Della Toffola is twice as fast as any side bag press, if clients really wish to remove press screens in between each press load, they would certainly have far more time to do so with any Della Toffola press compared to a side bag press operation.**



Similarly with bag changes. I understand a lot is being said by our competitors about the duration of what it takes to change a bag. Sure a bag change is inevitable yet how that is managed can occur many ways. As per discussions with some wineries we have run drills off season, if the notion of down time in harvest is such a dramatic concern for the sake of what is the cost of a bag (about Euro 6,000) why not change a bag in the down time/post or pre vintage period would be a suggestion. In any case, our experienced teams using a 240hl press takes around 5 – 6 hours. The larger 480hl press, due to the weight of the press bag, our customers potentially could take up to 7 – 8 hours. Yet those times are largely due by virtue that bags are not regularly changed and customers are not expert.

Our perspective is that a press is invested into as the winery has a requirement to extract juice. Without knowing the time frame the same skilled team would take to change one bag versus another let's just accept for the purposes of discussing this issue that changing a DT press bag may possibly take two to three hours more than a side bag press bag change as per our competitors comments. Given those time frames are the worst case, if a bag change is required every 7 to 8 years would someone seriously decide on a press investment disregarding all the major benefits as to actual press extraction?

The Della Toffola central membrane press is a very proven press technology that presses twice as fast as any side bag press, per press load presses significantly more volume, delivers a substantial greater proportion of extract as free run juice per press load and is faster and significantly more easier to clean. So a typical side bag 260hl press processes 55tns and turns around every 5.5 to 6 hours. This represents 9 tns/hr. The Della Toffola 240hl press processes 70-75tns and turns around in 3 hours delivering a median average of 24tn/hr. There is a subtle suggestion that the two or three additional hours being raised by competitors as being the significant problem for Della Toffola presses in respects to press bag change over times is arguably inconsequential to the more significant problems faced by side bag press operation cycle times, phenol and solids generation.

This all said the real story for press investments moving forward is somewhere very different. At a recent client meeting the question was asked, 'are there any new developments on the DT pressing front?'. The Della Toffola presses provide an extract juice 60% lower in suspended solids to side bag presses for whites and red winemaking. The Della Toffola press best enables an inline continuous drain separation of juice intake with reduced solids loadings than any press. This dynamic is influencing the effectiveness of juice clarification, down-stream with type and scale of investment towards inline continuous flotation and inline high solids recovery/cross flow technology spend. 'Spend' being the operative word! – Reduce the solids loadings at the press extraction point and that translates to more bang for buck investment potential with high solids separation and in line continuous clarification technology.

There is a lot of new, well-proven exciting technologies that are being adopted these last years. The advantages of Della Toffola presses compared to side bag presses are very clear. The real benefit of a Della Toffola press investment is the more efficient adoption to new technologies at the front-end winery for clarification and separation technologies. It is in this space that payback is being focused on, and it is the central membrane press that is central to achieving more fluency with the far wider narrative of achieving better quality and or more effective winemaking in winery operations.

## Della Toffola Central Membrane Air Bag Press

- Sizes from 1,200 L/drum (PE12) to 70,000 L/drum (PF700)
- Available in Closed Tank or Open slotted design
- Inflation and deflation of bag occurs from the centre of the drum, allowing the full 360° outer diameter of the drum surface to be used for juice separation
- This offers up to 100% drain screen area
- Pre-programmed automatic cycles, semi-automatic or fully manual control
- Greater screen area coverage results in better throughput – larger load in volumes and faster pressing cycle times. Plus improved juice and wine quality from less time on skins



# BASKET PRESSES

Basket presses are back and better than ever! Manual or hydraulic, manual or programmable, half a ton to 2.5 ton, the beauty of the basket press is that it's the winemaker who is hands-on making the press fraction decisions and not a computer program; the winemaker controls the rate of press, the total pressure and, most importantly, has continuous and immediate access to the press juice, in real time. Standing right at the press pan, the winemaker can continuously taste the juice/wine as it is being pressed, see the flow rate, smell and taste the wine, and tinker with the extraction rate to their heart's content.



## Electric Hydraulic Basket Press

- Range of 10 models from top quality Italian manufacturers
- From 130kg - 3500kg
- Enclosed hydraulic motor
- Longest press ram
- Hydraulic cage lifting accessory available
- Manual and/or programmable
  - Pre-set times and pressure
  - Pre-set maximum pressure
- Stainless steel or wooden baskets
- Push trolleys or forklift skids
- Extra baskets and trolleys
- Drain mats for faster low-solids pressing



## Hydopress

- Utilises water pressure for pressing (sample and trial batches)
- Available in 20, 40, 80 and 160 litre cage capacities
- Fully stainless steel cage
- Includes pressure gauge and food grade rubber tube
- 20, 40 and 80 litre models stand upright on three legged stand
- 160 litre model is available on a tilt frame



## Manual Ratchet Basket Press

- Available in 5 models, from 60kg to 200kg capacity
- Wooden basket with baked enamel rings
- Food grade epoxy coated drain plate
- Two speed hand ratchet system



## Manual Hydraulic Basket Press

- Available in 5 models, from 210kg to 670kg capacity
- Wooden basket with baked enamel or stainless rings
- Also available with full stainless steel basket
- Food grade epoxy coated drain plate
- Twin piston hydraulic head with pressure gauge
- Optional - wheels for ease of movement





# STALK MULCHERS

Our European suppliers offer specialist equipment and have over 50 years' experience in the wine industry. They offer a stalk mulcher capable of processing from 4 to 60 tons per hour, and most cleaning can be done without the removal of any mechanical parts.

## Stalk Mulchers

The machine, thanks to its innovative structure condenses into a small space a powerful cutting section and an effective evacuation system of the product that is directly loaded on a normal container pallet without any intervention by the operator (container not included).

The destemmer/crusher deposits stalks into the stalk mincer and over a path of 1.5 meters.

The machine is all stainless steel with the exception of the rotor and the roller are made of painted steel.



# 2. Fermentation

**FERMENTATION  
REFRIGERATION**

# Fermentation

**What is fermentation? It's more than the metabolic process of converting a carbohydrate into an alcohol or acid, much more than that. It's been called "sunlight into wine", spawned quips and brought forth poetry, and even gets an honourable mention throughout the Bible from Old Testament to New.**

At present we see a proliferation of wine styles, as winemakers push boundaries and tear up the rule books, looking backward to move forward, and trying new stuff. There's a re-invigoration of wine and cider, genres are being bent, the equivalent of punk music but expressed in winemaking.

At the same time winemaking technology has made remarkable strides, giving winemakers great ability to guide and control a deceptively simple process; sometimes this has even led to more better wines!

Fermentation is a natural and inherently simple process; as simple as pitching a ton of grapes or litres of apple juice into a fermenter of any shape, size, or material, and letting nature take its course. The winemakers role is to oversee the process and manage the complex chemical and biochemical transformations, maximizing and protecting flavor, texture, and aroma - to make the most accurate wine possible each time.

In the pages following look for tools to manage your fermentation process: controlling temperatures, must maceration, and wine and juice stabilization.



# FERMENTATION

What is fermentation? The metabolic process of converting a carbohydrate into an alcohol or acid. More than that however, it's been called "sunlight into wine", and spawned quips, brought forth poetry, and gets an honourable mention in the Bible from Old testament to New.

Temperature control, and other tools for managing your fermentation process are set out below...

## SOCMA Turbopigeur

- Efficient way to pump over without needing full supervision
- Sophisticated flooding action which simulates a punch down and effectively immerses the cap without mechanical damage
- Thorough but gentle, with low impact fountain action
- Easily cleanable, just by hosing with water
- Half the labour of pump overs
- Impossible to pump over the wrong tank
- Can be used in different modes to flood the cap, mix the tank and to suspend the lees

### TECHNICAL INFORMATION:

- The 1mt. Turbopigeur weighs 15kgs and the 2mt. version weighs 19kg's
- Speed variator – with reversible frequency giving complete flexibility
- Timer as standard
- Adjustable Elbow, to concentrate the flow in a determined trajectory
- 380 volts (1kW)



## Pneumatic Must Plunging System

- Standard sizes available to suit open fermentation tanks or variable capacity tanks
- Full stainless steel construction
- Automatic control timer for plunging paddles
- Pneumatic cylinder with air line tubes
- Provides quality cap management with fully programmable speed and timing variation
- Requires operation with a 4 bar compressor



## Della Toffola Bio-Thermocooler System

- Available in capacities of 5, 10, 15, 20, 30 and 60 tonne p/hr
- Submerges berries in a single rapid movement into an 85°C - 90 °C environment followed by instantaneous cooling – initiating a more efficient breakdown of the entire berry structure
- Inhibits damaging enzymes such as polyphenol oxidase and laccase
- Increased anthocyanins, tannins, polyphenols, flavour and aroma compounds
- Reduction of on-skin fermentation time to increase winery throughput and tank space during processing of red wine
- Can be used for concentrating and evaporating processes
- Technology can be used at lower temperatures and integrated into moderate thermal vinification practices



# REFRIGERATION

Refrigeration options to suit your specific needs, including monobloc, tube-in-tube and continuous tartrate stabilisation.

## Della Toffola Monobloc

- Wide range of models, from 12,500 litre to 56,500 litre
- Alloy outer covering
- Units include compressor and reverse cycle fans
- Heating elements protects the evaporator
- Thermostatically temperature controlled to turn itself on and off
- Complete refrigeration designs include: total PLC control, separate glycol storage tank, separate compressor and all installation requirements



## Della Toffola Immersion Heating/ Cooling Plates

- Available in 13 sizes, from 0.45 (m<sup>2</sup>) to 4.4 (m<sup>2</sup>) surface area
- Manufactured fully in AISI 304 stainless steel
- Electro-polished outside
- Threaded coupling
- Also available in a range of widths upon request
- Designed to be operated in conjunction with the refrigeration monoblocs

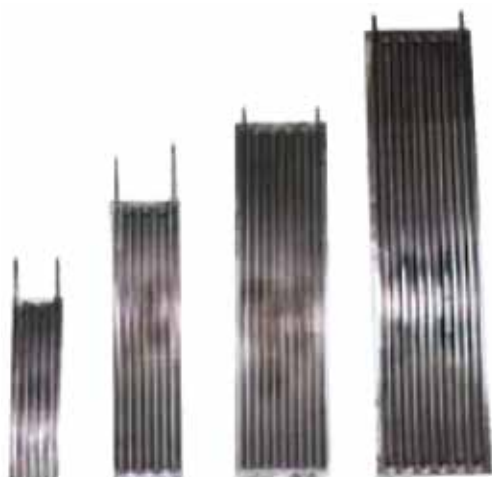

## RMA Cooler

- Energy-storing water coolers comprises single air-condensed units compressors.
- All models include a water storage tank and circulation pump
- Microprocessor control
- These units are suitable for installing out of doors
- Also available in a heat pump version
- Energy Saving - Thermostat stops the cooler when the temperature drops below a preset threshold (set point) and starts it again when the temperature exceeds the set point value by a given differential





## Continuous Tartrate Stabilisation - Polar System

- Extensive savings through reduced energy use, cleaning costs, water usage and waste management stream - in comparison to traditional stabilisation methods
- Wide range of models with varying capacity - from 1,000L/hr (P12) to 20,000 L/hr (P200)
- The stabilisation process is essentially implemented without any addition of potassium bitartrate crystals
- Negates the need for low temperature tank farm refrigeration
- Managed on-line by Polar Point Laboratory technology equipment - quickly and reliably determines the specific conductivity and separation temperature
- Automatic dosing of cream of tartar on the basis of the analytical data provided by the Polar Point system
- Complete plant set up, reliable and easy to use
- Stability with little to no loss of wine

## Central Group Fridge

### MOD "T" WITH HEAT PUMP MOD "H"

- Insulated storage tank
- Circulation pump in stainless steel bars par 3 mod P3 Prevalence 2.5 bar
- Compressor soundproof and airtight
- Kit Manual water loading
- Grid-Wire Battery Protection Condensing
- Brine System Brine Temperature -10°C
- Digital Microprocessor Control Chiller 400 volt 50 Hz three-phase
- Refrigerant gas R-410a (Eco-Friendly)
- **Mod. "T" Mini Group** (Performance calculated Environment temperature 35°C inlet temperature +12°C brine outlet 7°C)
- **Model "H" with Heat Pump** (Performance calculated temperature 7°C water temperature 40/45°C)



## RAF/PC Coolers

Air-condensed liquid coolers with axial fans

- Designed to work in systems with a low water content
- Suitable for installation out of doors
- A reliable alternative to the installation of storage tanks, enabling at the same time an accurate control of the water temperature
- Units are delivered already filled with antifreeze oil and a charge of refrigerant gas
- Units are charged with environment-friendly R410A refrigerant
- A heat pump version is also available.
- At the installation it is only necessary to connect the water and electrical energy supplies
- In the subsequent commissioning stage, all the operator needs to do is establish the temperature setpoint

The systems are complete with an electronic control keyboard for complete and highly advanced adjustments. Complete management of alarms via the display, or a separate PC.



## Della Toffola Tube-in-Tube Heat Exchanger

- Manufactured completely from stainless steel pipes and mounted on stainless steel frame
- Suitable for must or juice
- Available in a range of sizes, and can be configured to your specific requirements
- Pipes are easily accessible for maintenance, cleaning, repair or adjustment
- Systems can easily be modified with the addition or subtraction of pipes as requirements change
- Includes 2 thermometers





## CEP-Italy Tube in Tube Heat Exchanger



- Modular design suitable for heating / cooling must, juice, and wine
- Easy access to the pipes for cleaning
- Stainless steel AISI 304
- Wine/juice tube encourages helical flow to improve the heat exchange
- From 2 metre to 6 metre tubes

### Available in

4 tube	6 tube
8 tube	10 tube
12 tube	14 tube
16 tube	18 tube
20 tube	24 tube



## Custom Temperature Control Solutions

Della Toffola Group manufactures complete refrigeration systems with a very broad range of options, even computer-aided monitoring, for the management and control of the temperature of musts and wines, at every stage of the winemaking process.

Designed and manufactured to meet YOUR needs.



# 3. Maturation & Storage

AMPHORAE  
TANKS

# Artenova Amphorae

Artenova amphorae are all handcrafted from Tuscan clay, sourced from Impruneta in Tuscany. Since the days of Ancient Greece man has used clay vessels for storing wine. Terracotta amphorae, arriving with the Greeks and widely distributed in Italy by the Etruscans, were the first true containers for fermented grape juice.

Today we aim to revive what has been one of the oldest techniques for making and storing wine in human history, to give birth to a new harmonious balance between wine and nature. Artenova has furthered this interesting experimentation by putting into production a series of handmade vessels, crafted in the traditional way, but at the same time designed for professional winery use.

Unlike oak, terracotta has no flavor, aroma, or indeed any textural impact, so these vessels impart nothing extra to the wine. It does though, like oak, have the advantage of offering some form of micro-porosity enabling the wine to breathe. The extraordinary thermal insulation capacity

of Terracotta, and the now famous chemical and physical characteristics of the Impruneta clay, allows for the perfect storage of wine. The amphorae have integrated stainless steel lids, so post-fermentation they can also be used as a secure maturation vessel.

An inner lining can be applied to the amphorae, made from natural elements such as beeswax, to form a barrier minimizing oxygenation through walls of the amphora.



# AMPHORAE

Made in Italy.

## Artenova Terracotta Amphorae

Artenova amphorae are all handcraft from Tuscan clay. One of the benefits of the amphorae is, that unlike wooden barrels, terracotta has no flavour of its own so imparts nothing to the wine. It does though, like oak, have the advantage of offering some form of micro-porosity enabling the wine to breath. These unique vessels also come with stainless steel lids so post fermentation, they can also be used as a secure storage vessel.

Volume: 800lts	Volume: 500lts	Volume: 300lts
<b>Dimensions:</b>	<b>Dimensions:</b>	<b>Dimensions:</b>
<b>Height:</b> 145cm	<b>Height:</b> 130cm	<b>Height:</b> 115cm
<b>Width:</b> 118cm	<b>Width:</b> 95cm	<b>Width:</b> 85cm
<b>Weight:</b> 200kg	<b>Weight:</b> 170kg	<b>Weight:</b> 40kg







# TANKS

A range of variable capacity and static stainless steel tanks available.

## Stainless Steel Tanks

- All tanks are fabricated in heavy duty gauge 304 or 316 steel
- All supplied fittings and lids are manufactured in the higher quality 316 stainless steel
- Sterile welding and circular polish ensures easy cleaning for longer aesthetic presentation of tank
- Choice of lids, fixed or variable capacity (VC) kit. All variable capacity tanks have a reinforced rim to prevent warping
- Sizes available from 100 to 25,000 litre capacity



## Fermentation Vats

- Vats available in 8 sizes from 110 to 1,500 litre capacity
- Lids are available for the 500, 750 and 1,000 litre vats only
- Manufactured in heat resistant food grade polypropylene
- Available in burgundy (white subject to availability)
- Optional tap and straining screen



# 4. Cooperage

**TONNELLERIE  
ROUSSEAU  
BARREL  
WASHING**



# Tonnellerie Rousseau

Since its creation back in 1954, Tonnellerie Rousseau has been committed to building reliable, quality products, always developed with winemakers all over the world, and in line with long-standing traditions – but they did not forget to add their trademark with a touch of modernity and dynamism!

Because they manufacture both barrels and large format tanks and casks, they have developed a wide range of solutions for vinification and maturation of your wines. The range includes a wide variety of products: barrels from 57 to 600 L, oval and round casks, vinification and/or maturation tanks. Their large formats are both available with standard or customised dimensions, to fit in your cellar perfectly.

They are proud to have trained since their beginnings, 11 Meilleurs Ouvriers de France aka “MOF” (“Best Craftsmen of France”) to offer customers soundly and precisely made products. Among their 11 MOF, let us introduce Julien Rousseau, the founder of the company, Jean-Marie Rousseau, CEO, and his son Jean-Christophe, Manager of the large formats workshop – this is a unique achievement in the world of cooperage!

If working in an authentic, traditional way remains their motto, they also pay a lot of attention to innovation: since 2004, two engineers have been designing effective and convenient solutions for ageing in oak. Their team always keep a strategic watch in the market and are looking for out-of-the-box solutions. Various tests (on oak, toasting, accessories...) are carried out on a regular basis.

In order to better fulfil your needs, the cooperage has also obtained the ISO 22000 certificate in 2013 – one of the strictest certificates in terms of food safety and traceability. And since they’ve always been committed to sustainable development, they also have obtained the PEFC certificate in 2012.

**New Zealand  
distribution only**



## Round & Oval Casks

- Casks from 1000 litre to 40,000 litre
- Up to 60cm of stave wood, naturally curved, structurally sound
- Drain doors (placed in a single central stave - No leakage)
- Drain valves and racking valves
- Top Central Door available



## Conical Trunk Vats

From 1000 to 20,000 (up to 150,000 by special order)

Available with:

- Stainless drainage door
- Drain valve
- Racking valve
- Internal cooling/heating plates
- Fixed pump-over tubes
- Steel lid with man door

## Expert Range

The Expert Range is characterised by a special seasoning of woods, and a special toasting developed for these barrels, in order to create moderate oak impact, and a quick integration wine / oak. Perfect for short maturations, between 6 and 10 months. They make their own selection of wood (French oak) for this range.



## Traditional Range

The Traditional Range was the first range ever created by Tonnellerie Rousseau! Launched at the end of the 90s, tested and approved since then, it really symbolises their experience and know-how. It's been developed with Burgundy winemakers. Our goal was clearly not to concentrate on a specific forest and to bring more consistency in oak profile.



## Confidential Range

The Confidential range brings to light the oaks grown in the state-owned forests of Tronçais, Bertranges, and Châtillon... These names evoke the most prestigious oak forests of France, and perhaps Europe! They have set up a special supply chain for these barrels, in order to guarantee their origin. Due to the scarcity of oaks, the barrels of our Confidential Range are only available in limited amounts and in 228 L.



## Exceptional Range

You will find in the Exceptional Range their high-end barrels, recommended for your wines with great potential. Discover their special barrels: the famous Video®, a barrel with extra tight grains, Alto, its little brother that has joined the permanent range recently, and Hexagone, a barrel that highlights our French forests. The quality of Rousseau's barrels, with a little something extra!



## Large Format

Ask us about your requirements no matter how big – anything is possible!



# BARREL WASHING

High quality automated barrel washing, featuring complete automatic systems, automatic barrel washers, semi-automatic and manual barrel washers.

## Ekinsa Automatic Systems

- Ease of use with fully programmable automatic process
- High pressure cleaning
- Process includes emptying, steaming, washing, sulphuring and filling
- Complete system design
- Consulting, installations, commissioning, training and maintenance available



## Modular Barrel Washers



## Modular Barrel Washers

- Available in 2, 3 and 4 barrel configurations for small to medium wineries
- Single barrel configuration also available in manual and semi-automatic format for the smaller wineries
- Available for all type of racks - complete, efficient and easy to operate
- Full stainless steel construction with adjustable legs for height and level correction
- Touch panel controls and adjusts machine operations - includes emergency stop button, electrical protections, display and timer controls
- Automatic system for barrel's hole centering
- Lees recovery system (include racking pump)
- Installation for high pressure steam injection
- Installation for water and ozone injection
- Low pressure shower to refrigerate barrels after washing

## Counterweight & Semi-Automatic Barrel Washers

The manual barrel cleaner is a portable device fitted with two multi-directional rotation jets of high-pressure cold or hot water to cover all points inside a barrel. All sensitive parts of the machine (motor, reduction gears, etc.) are protected from the water.

- From 225 to 600 litres
- Counterweight loading (manual or electric) available
- Programmable controller available
- Steam unit available
- Ozone modular unit available
- Semi-automated 2, 3, 4, and continuous barrel cleaning units available



## Single Barrel Washer

Portable and versatile single barrel head washer.

The barrel cleaner comes with motor, spray head and trolley.

- An additional pressure cleaner to run the system is required
- Recommended pressure cleaner to be used in conjunction with the above mentioned equipment is an 12 - 15 litre/min. pump with pressure up to 2400 P.S.I.
- Fitted with a conical spray head for easy insertion into bung hole
- Complete stainless steel
- Minimal water consumption
- Connects to any high pressure system
- Two spray nozzles driven by an electric geared motor
- Rotates on horizontal and vertical axis for complete coverage
- Compact and easy to handle.

### TECHNICAL INFO:

- **Power requirement:** 240v or 24v or 110v AC or compressed air
- **Working pressure:** Up to 180bar
- **Flow rate:** Optimal 15L/m
- **Working temp:** Up to 150°C

**5.**

# **Filtration Clarification**

**FILTERS**

**SEPARATION/  
CLARIFICATION**

**FLOTATION**

# Filtration

**Every customer will filter their wines in a different way - like a lot of winemaking practises, the decision whether and to what extent one should filter should be determined by the goals at the end of the process.**

Filtration makes a wine “brighter” meaning clearer, so the winery may decide to filter for strictly cosmetic reasons. On the other hand, a winery may decide not to filter their wines because they feel that too much of the wine is left on the filter media, and that the unfiltered wines taste better and have superior mouth feel.

There is no single correct answer; winemakers have to decide for themselves what is right for their product. Filtration technology has provided winemakers with a method of creating wine stability in various styles. Filtration is, basically, passing wine through a small-enough medium to remove undesirable elements. But does this remove too much of what makes the wine attractive to the consumer?

As with fining, some winemakers argue that filtration can have a negative impact on flavour and aroma, while others suggest that without filtration something else will negate a wines potential.

Most winemakers straddle this dilemma by trying to filter no more than necessary – but always filtering when it is necessary. That standard leaves a lot of room for judgement ....and means that winemakers really have to know what’s up with their wines to make intelligent decisions.

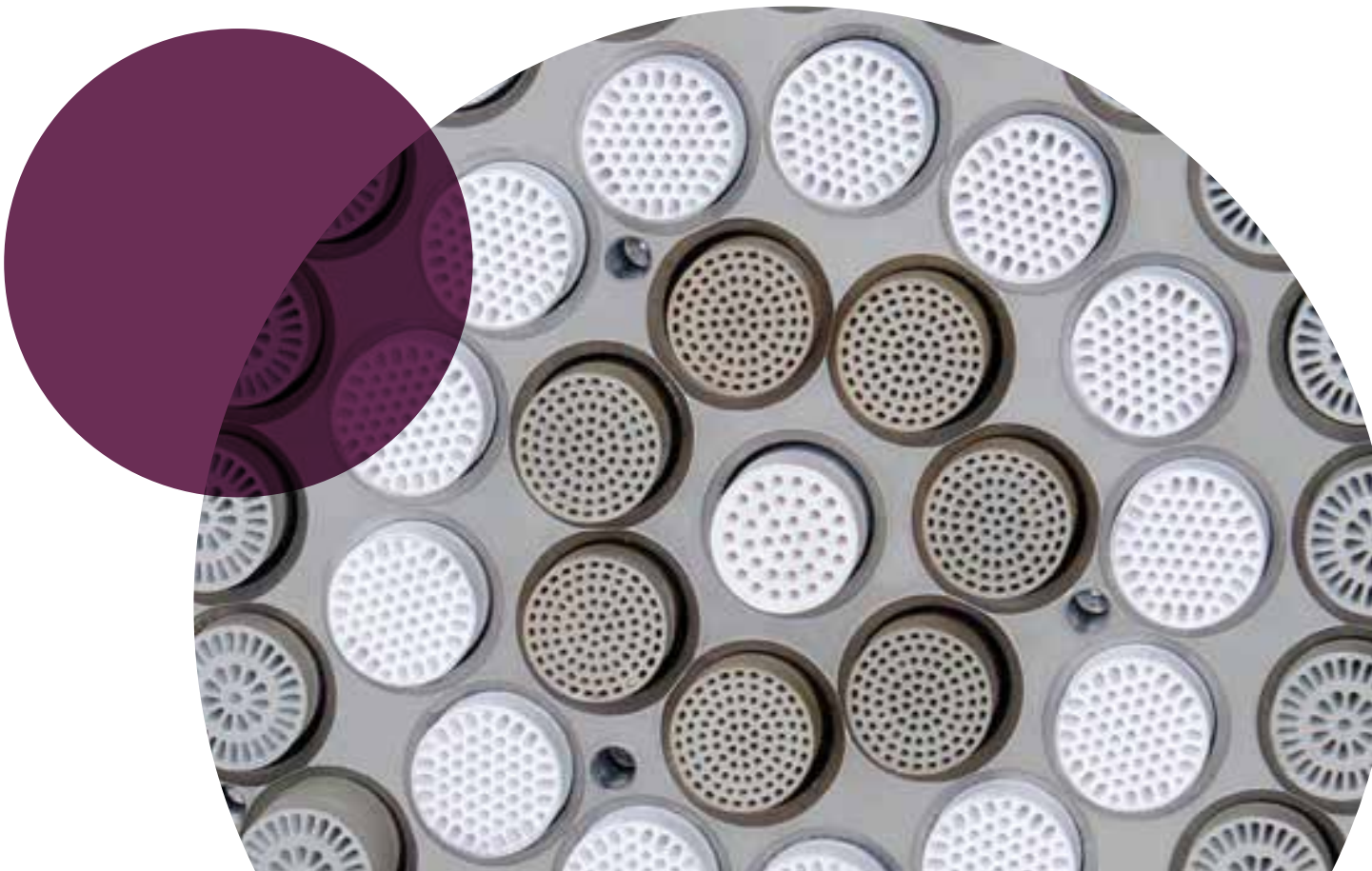

# Crossflow benefits

We have the most durable membranes in the market, titanium core with a baked ceramic membrane. This provides unparalleled pore size accuracy and no pore degradation.

We guarantee our membranes for 10 years, no fine print!

- The filters are fully automatic in their loading, filtration, discharging and regeneration phases
- All filtration parameters can be preset each filtration run - temperature, pressure, and flow rates - eliminating heat build-up, or a stalled filtration, or excessive shearing
- Membrane pore sizes are available in 0.2 micron, 0.6 micron, 0.8 micron, and 1.0 micron
- The ease of operation and complete control via automated settings has freed a cellar worker from brooding over a filter for 8 - 10 hours a day, or staying late to finish...
- With the Della Toffola filters you are able to hot water wash, or use whichever chemical you want to, as often as you want to
- Any single membrane can be replaced - so if a membrane is compromised, we can remove it and replace, rather than plugging it in situ and leaving a wine-filled noodle in the machine - therefore any cross contamination between products in the filter is eliminated, guaranteed, for the life of the ceramic membrane. This feature alone makes Della Toffola an obvious choice
- We have significant industry coverage and a talented team of factory trained technicians, spare parts and support people if you should ever need

- Our technicians will install, and train you on operating the filter
- Our filters can handle 0.5gms/lit bentonite in solution, Carbon, PVPP, KHT and still run at efficient workflows; some other crossflow filters void warranty's with these products
- CIP with hot water and/or steam, high strength caustic solutions, phosphoric or Nitric acid
- Able to filter sparkling wine - 9 bar capacity for the membrane and up to 10 bar capacity on the machine

## DELLA TOFFOLA "OMNIA" HIGH SOLIDS CROSSFLOW

We can go from incalculable NTU's to under 1 in a single pass, from flotation lees, juice bottoms, juice lees, wine lees

- Wines with 0 NTU turbidity, can be obtained by starting from values ranging from 25 to 1,000+ NTU
- Filtration of clarification lees containing substances such as carbon, bentonite, casein, etc. with final filtrate recovery of over 80%
- Self-monitoring system with the display on a graphic screen of the status of the pumps, valves, pressures, instantaneous and mean flow rates, temperature, filtering time, liters filtered, viscosity and status of the alarms

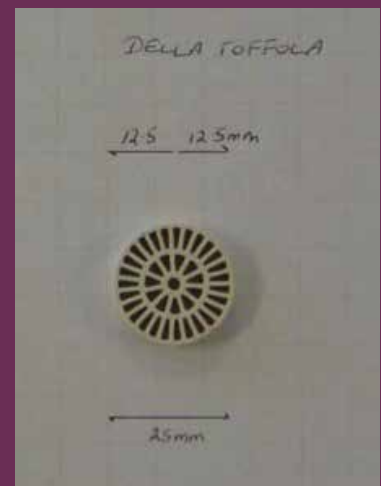



# FILTERS

An extensive range of filters, including cartridge, plate and frame, RDV, earth and cross flow. Della Toffola water filtration solutions are also available.

## OMNIA Cross Flow Filter

Produced in a range from the OMNIA 50 to the OMNIA 1 680 Model, these fully automated filters are particularly suited to the processing of all liquids with high suspended solids. OMNIA Series filters are designed and constructed for the efficient filtration of cider, juices, grape must lees, wine lees after fermentation, wine lees after clarification, and both clarified and non-clarified wines.



## Della Toffola Horizontal Earth

- 'A' series available in filtration area sizing of 20-700m<sup>2</sup> plus, achieved by its modular design feature (can be sized to specification) – bypass function also allows for small batch processing
- New fully automated entry level 'N' series now available in filtration area sizing of 10-170m<sup>2</sup> at competitive price points
- Fully automated continuous filtration – requires no additional filtration media
- Able to filter juice, must and finished wines, including sparkling
- Together with the automated back flush system, allows for greater consistency of filtration over the broadest range of wine products

## Della Toffola Microfiltration Cartridges

- Cartridge filter systems used prior to bottling for final filtration of wines
- Complete stainless steel construction of housing
- Available in single cartridge or lenticular modules
- Sample valves, sterile pressure gauges and sight glasses included on inlet and outlet
- All connection types available including BSM, BSP and Triclover
- Range of cartridges to suit this system are available



## Della Toffola Plate & Frame

- Noryl food grade plastic plates 40cm x 40cm
- Available in models from 2,000 L/hr (A2) to 10,000 L/hr (A10) maximum output
- Full stainless steel body
- Sight glasses, sample valves, pressure gauges and butterfly valves included on inlet and outlet
- Includes stainless steel drip tray
- Fitted with wheels for ease of movement
- Manual screw closure included



## 20 x 20 Plate & Frame Filter

- Fully stainless steel body
- Noryl food grade plastic plates 20cm X 20cm
- Units include pressure gauge on inlet
- Fitted with wheels for easy movement
- Stainless steel drip tray
- 19mm BSP male inlet/outlet, optional range of adaptors available if required



# SEPARATION / CLARIFICATION

## Seital Range Of Centrifuges

- Designed specifically for winery applications
- Available from 1,000 L/hr (111S) to 40,000 L/hr (501S)
- Skid-mount design offering ease of installation, significantly reduced costs of installation and site preparation
- Extremely efficient separation/clarification with minute carry over solids in wine thus reducing down line filtration costs/requirements
- Variable speed with low power use (37/45kW) providing excellent savings
- Semi and fully automated models with easy touch screen interface
- Remote access and monitoring capabilities
- Highly efficient with electric emergency breaking
- Very high flow clarification rates - 5,200 rpm



# FLOTATION

Della Toffola Flotation Systems are available in static and continuous formats, providing a unique clarifying system for must and juices that need to be fermented or concentrated.

## Della Toffola Flotation System

- Available in Model FLN1(CV) 20,000 L/hr and FLN2(CV) 30,000 L/hr capacity
- Fabricated in 304 stainless steel
- Saturator units are fully self contained and wheel mounted for easy movement
- Includes up to 3 peristaltic dosing pumps for addition of fining agents (2 as standard on static units)
- Includes centrifugal feed pump
- Continuous flotation system includes separation tank complete with revolving brush system
- Separates solids in juice to reduce hold up time and refrigeration to cold settle juice, reduces lees volumes to RDV



# 6. Pumps

The background features a light purple color with several overlapping circles. A large, semi-transparent circle is at the top left. A smaller, solid purple circle is at the bottom right. A third circle at the bottom left is filled with a pattern of small, light purple dots.

# Pumps

Conscientious winemakers recognize pumps' important roles in maintaining wine quality. Many wineries rightly attempt to minimize pumping by taking advantage of gravity and/or the trusty forklift, but it's not usually practical to eliminate all pumping.

Pumps might seem like trivial equipment among the destemmers, sorting tables, presses and tanks, but the importance of choosing the proper pump stems from the need to treat must and wine gently.

## PERISTALTIC PUMPS

- There is no contact between the wine and the mechanical parts
- All parts of peristaltic pumps in contact with the product are made of inert stainless steel and food-grade rubber
- They provide very delicate transfer of wine and are self-priming
- They do not turn at high revolutions (which tend to beat or crush must), do not introduce oxygen
- Can be used to transfer solids and liquids
- They also can provide reversible flow, precise control of product transfer and can be run dry without damage
- These pumps can transfer from 1 to 40 tons of liquid or liquids and solids per hour
- One popular accessory is a hopper with a feed screw that permits the pump to be used under a destemmer

## VOLUMETRIC PUMPS - MONO PUMPS

- Progressive cavity pumps for portable and stationary applications
- Suitable for transferring berries, must and even pomace
- Gently convey thin and high viscosity products, with or without solids, as well as cold or high temperature products without pulsation and with minimal shear

## FLEXIBLE IMPELLOR PUMPS

- A standard in the industry
- Excellent for transferring wine, filtering and bottling
- Can operate at low revolutions, yet produce high pressure with very low oxygen pick-up

## PISTON PUMPS

- Steel piston pumps offer elevated output and smooth, balanced flow without shaking, even with hard-to-process liquids

## CENTRIFUGAL PUMPS

- High capacity pump
- Can be "closed off against"
- Impellers in rubber or steel

## AIR-OPERATED DIAPHRAGM PUMPS

- No crevices or dead areas to eliminate unwanted microbial activity
- General transfer, pumpover processes, blending, barrel feeding/topping, filter feed, lees handling and filler feed

# PUMPS

An extensive range of peristaltic, positive displacement and centrifugal pumps. Brands include Della Toffola, CEP-Italy, TEM, Tecnicapompe and Liverani.

## Della Toffola Open Throat Must Pump

- Fully stainless steel body
- Highly resistant thermoplastic elliptical rotor
- Extra deep collection hopper
- Anti-vibration device for firm stability while running
- Splash proof controls
- Available in a range of models, from 500-2,500 L/hr (PPC25) to 12,000-60,000 L/hr (PPC600)
- Available in 4 sizes, from 9-11 tonne p/hr to 23-28 tonne p/hr
- All contact parts are made from stainless steel and food grade silicon
- Self priming
- All transferred material has no contact with mechanical parts
- Pump can be run dry without any adverse affects
- Electronic inverter allows continuous regulation of flow rate



## Della Toffola Peristaltic Pumps

- High self priming capability
- Can reverse flow
- Can "run Dry" with no negative effects
- Inbuilt inverter controls flow rate - allowing for excellent accuracy in dosing
- Hopper with screw feed available
- Perfect for gentle handling of musts and high solids
- From 600 litres per hour to 93,000 litres per hour



## Piston Pumps

- From 4 tons per hour to 95 tons per hour
- Excellent Must and solids pump
- Comes on a steel trolley
- Stainless steel 316 pump body
- Pumps are reversible
- Wired in remote control available
- Radio control remote available



## Flexible Impellor Pumps

- From 600 litre per hour to 105,000 litres per hour
- Comes on a stainless steel trolley
- Neoprene food grade impellor
- Stainless steel 304 pump body
- Bypass can be fitted
- Pumps are reversible
- Wired in remote control available
- Radio control remote available



## Mono CP Range - Small Liquid Transfer Pump

- Helical rotor positive displacement pump for the transfer of juice or wine
- Tough acetyl co-polymer plastic housing
- Stainless steel internal rotating parts
- Pulsation free operation - a result of the uniform flow rate
- Low rotor revolutions facilitates gentle liquid transfer
- Simple and easy to clean and maintain



## Della Toffola Mohno Pumps

All purpose Mohno Pump for transferring liquids in the beer, wine, and juice industries

- Made from 304 Stainless Steel
- Integrated sprung bypass for delivery pressure control
- Gentle pumping action from special hollow rotor
- Self priming capacity up to 6m
- Two speed or can be supplied with an inverter
- Optional 'run dry' cut-out switch
- 14 models from 1250 litres per hour up to 50,000 litres per hour



# 7. Distillation

The background features a solid dark red color. It is decorated with several overlapping circles of varying sizes and shades of red. One large circle is in the upper left, another medium circle is in the middle right, and a third circle in the lower left is filled with a pattern of small, lighter red dots.





# DISTILLATION

## The Craft & Co

With a fully functioning distillery at The Craft & Co, Australia, we have an amazing resource to share with distillation customers.

The distillery at the Craft & Co is built to provide support to the craft spirit industry in a few key areas:

- Education – How to distil, Safety and Distillation. Managing flavour in the Distillery.
- R & D – we can work with you to perfect recipes and distillation plans before your still is commissioned, cutting down-time and ensuring that you can begin producing spirits from day one.
- Brand Incubation – We can work with new brands to get their product to market before having to outlay the large cost of building their own distillery. This can assist with cash flow, R&D, planning permits and route to market.
- Contract Distillation – We are currently working with several independent producers and hospitality venues to create products specifically for them. We would love to talk about your project.

We are the only distillation equipment supplier with a fully operational distillery where you can experiment and train before turning the switches on your own still.

### SUPPORT ON SITE

Our team are also skilled and ready to provide commissioning and set up support with:

- Full service commissioning of stills, bottling solutions and distillery set up.
- Project design planning for distillery layout and OH&S
- On site distillation training in your distillery.
- R & D in partnership with you at your distillery to assist in creating recipes and distillation plans.
- Allied industries network hub – bottles, closures, boxes, botanical supplies, raw materials, labels, designers, whatever you need, we can put you in contact with a great network.
- Knowledge resource for recipe creation with our house distiller. We love to share what we do and we share all the recipes for the Craft & Co house spirits with our partner businesses.





The stills we supply are a very high quality still and they are constructed around efficiency of vapour control and reflux, two methods of control for quality product.

With the initial reflux happening in the copper helmet at the top of the still this gives a softness to the spirit and helps take away harsh characters. The shape of the helmet on a still is designed to release pressure and create condensation. This design also helps concentrate heads and has the ability to bring flavour across. The use of copper is very important with the contact with the vapour at around 40%ABV being all about redox and pulling out SO<sub>2</sub> characters.

Our suppliers have over 200 years of experience with the construction of stills, the height of the swan neck is matched to the Lyne arm tubing. The drop from the height of the swan neck down to the bottom of the reflux is in tune for that vapour management. The dephlegmator is an important part of that design being able to give more control of the vapours, this helps with repeatable results and ease of use. More importantly they are a very practical design, think pneumatic large openings for discharge, think steam jackets for ensuring product does not burn in the pot, clean in place systems to avoid spending as much time cleaning.

We have different models of still enabling us to offer something suitable for many products and offering versatility in running, as well as being able to offer variations on those models.

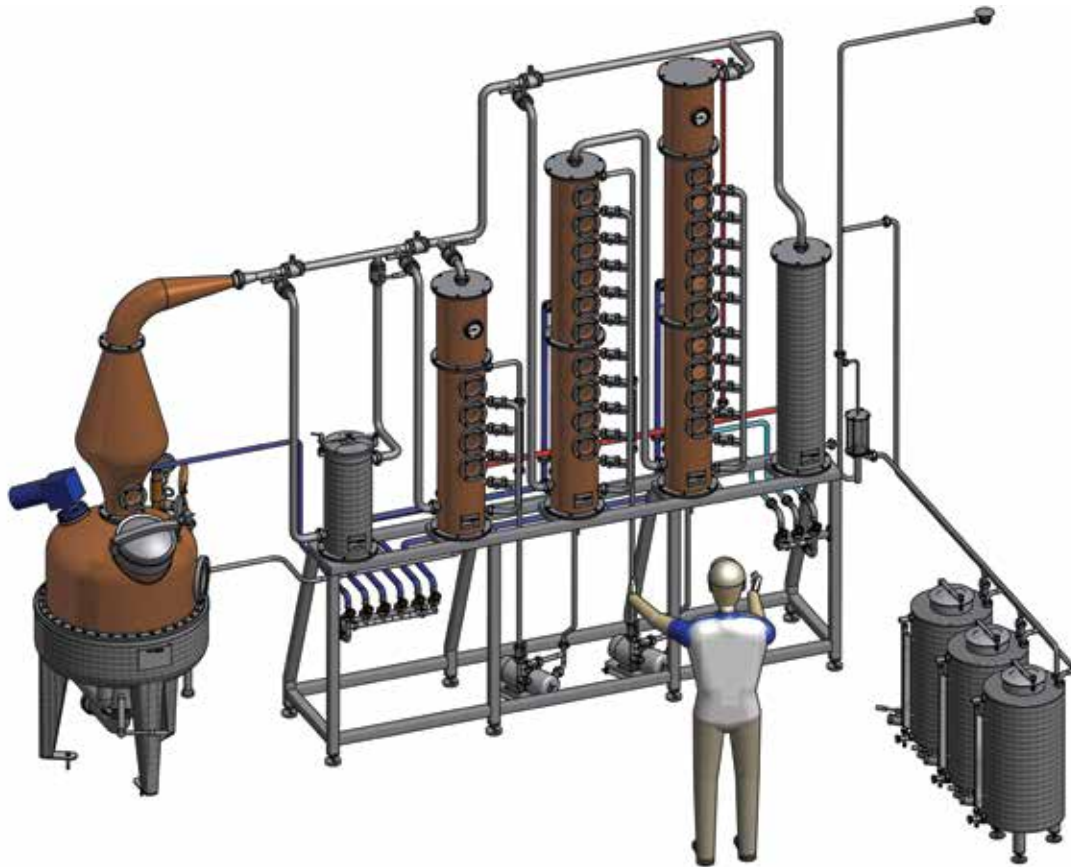
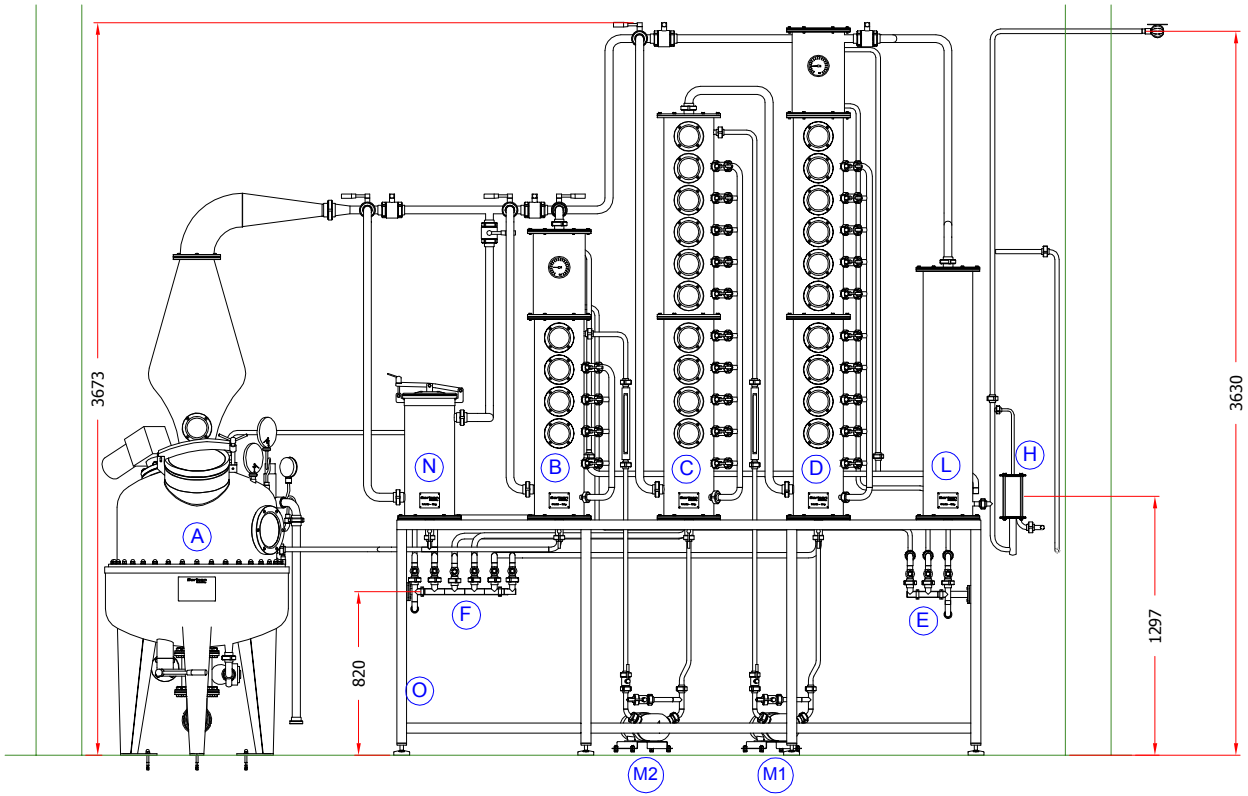



## Vitis are able to facilitate the process from beginning to end – from licensing applications through to developing recipes and refining your product, and teaching you how to distil properly.

Both continuous and discontinuous (pot) stills, steam or electric, and custom built to your specification; size, style and design matched to your business needs.

A genuine “turn-key” solutions provider, we work with customers through every stage of the process:

- Industrial design of layout,
- Council planning for liquor license, managing your waste water and boiler design and installation
- ATO licence
- Commissioning your still
- Fully training your local techs to troubleshoot and operate
- Our house master distiller is available to train and distil with you

Our role is to bring together all of the expertise within our company to help a potential customer get the product that they need and want. We'll work as your project manager to help smooth the path to obtaining a still.

# 8. Sparkling Wine

The background is a solid dark red color. It features three large, overlapping circles. The top-left circle is a darker shade of red. The middle-right circle is a slightly lighter shade of red. The bottom-left circle is filled with a pattern of small, light-colored dots.



# SPARKLING WINE

A specific range of equipment for the emerging sparkling wine segment.

## Sirio Aliberti High Pressure Tanks

- SIRIO ALIBERTI designs and produces highly reliable pressure tanks
- Pressure tanks are tested and certified in all phases of production
- Available in 316/304 stainless-steel pressure tanks
- Insulated pressure tanks can be produced in polyurethane-stainless steel, with satin or flower patterned finish
- Carbon steel pressure tanks are treated on the inside by sanding to grade SA3 and cold or stove enameled
- SIRIO ALIBERTI also produces isobaric samplers, batchers in stainless steel tested at 8 bar, and stainless steel saturators



## Neck Freezing Machines

Machine completely built in stainless steel, equipped within 3 positions located onto a fixed round surface.

- Bottle neck freezers for Champenoised method. To clarify wine after the fermentation in the bottle.
- To reduce the glycol temperatures to as low 25/30
- Electronic thermostat for temperature adjustment
- Stainless steel frame mounted on wheels
- Very easy to operate, delivered tested, guaranteed and ready for use
- Standard spare part available worldwide
- 7 years of guarantee



### FUNCTIONING

- The operator manually positions the bottle up side down in the machines holes and manually picks them up after freezing
- Glycol ethylene operated
- Stainless steel body

**3 head** unit has a fixed plate a three phase motor weights approx. 12kg's and will produce approximately 15-20 bottles per hour

**7 head** unit has a fixed plate a three phase motor weights approx. 30kg's and will produce approximately 30-45 bottles per hour

**32 head** unit has a three phase motor weighs approx. 80kg's and will produce approximately 120-180 bottles per hour



## Semi Automatic Disgorging - Dosing - Filling

- 150 to 500 bottles p/hr
- Fabricated completely in stainless steel
- This unit is able to dose, traditional disgorge and dose, ice disgorge and dose, or method disgorge and dose.
- Unit is manually loaded
- Capable of processing 375ml, 750ml and magnum size champagne bottles as well as other traditional bottle shapes
- Single disgorging arm controls the removal of the bidule and crown cap to reduce product losses
- Units are easy to clean and sterilise



## Automatic Disgorging - Dosing - Filling

- 500 to 800 bottles p/hr
- Fully automated disgorging and dosing unit
- Capable of processing 375ml, 750ml and magnum size champagne bottles as well as other traditional bottle shapes
- Single disgorging arm controls the removal of the bidule and crown cap to reduce product losses
- Single adjustable emptying spout
- Two adjustable levelling spouts ranging from 55 to 100mm
- Larger rotary type disgorging, dosing and filling machines from 1,500 to 2,500 bottles per hour also available



## Semi Automatic Corking & Muselet Applicator Workstation

- Bottle capacity up to 500 p/hr
- Free standing unit fabricated completely in stainless steel
- Equipped with mushroom corking machine and muselet applicator
- Manually loaded bottles onto both corker and muselet applicator
- Automatic bottle lifting plates
- Pedal activated corker control
- Push button muselet control
- Wheel mounted



# 9. Bottling

The background is a solid red color. It features three overlapping circles of varying sizes and positions. The top-left circle is the largest and is semi-transparent. The middle-right circle is smaller and is solid red. The bottom-left circle is the smallest and contains a pattern of small, light-red dots.



# BOTTLING

The end of the line - where your hard work, dreams, artistic vision, the cracked hands and bruised shins - the efforts of the team from harvest crew through to the winemakers chair; the bottling is where the magic is packaged. You'll want to do this part with as much attention to detail as all the rest.

We offer the most comprehensive range of equipment, whether you have made 1 ton or over 200,000 tons. Turnkey solutions and single component installations, we have a specialized bottling/canning/engineering division to advise, design, and make it work at your place.

- Manual 2, 4, 6 and 8 head fillers, cappers, corkers, capsulers
- Stand alone cappers and corkers
- Manual and Semi automatic labellers
- Small Monobloc rinser/filler/capper-corker/labeler units to manage 500 - 1500 bottles per hour - right through to the fully automated 35,000+ bottles per hour
  - Customizable double evacuation, gas insertion
  - Dual capper/corker turrets
- Counter-pressure canners
- Palletisers and de-palletisers
- Box-forming, filling, and emptying machines
- Printers
- Complete line design and automation

## Work Station Filler

Available in 2 head - 8 head, free-standing (as pictured) or bench top, with options of filters, electronic or manual floats, and in-built pumps.

- Complete stainless steel free standing filler
- Large 30 and 60 litre header tanks
- Four or six head filling nozzles with volume control and regulator
- Liquid and inert gas overflow tubes
- Fully adjustable bottle and filling heights



## Bench Gravity Filler

- Complete stainless steel gravity filler
- Large 30 or 60 litre header tanks
- Two, four or six head filling nozzles with volume control and regulator
- Liquid and inert gas overflow tubes
- Fully adjustable bottle and filling heights



## Semi Automatic Mep Corker

- Fast and precise closure
- Suitable for synthetic and natural corks 22 to 26mm diameter
- Manufactured entirely of 304 stainless steel
- P12 Pneumatic Corker with hopper (bench unit)
- P45 Electric Corker with gas purge (bench unit)
- P35 Electric Corker with vacuum (floor unit)



## Enomatic Vacuum Bottle Filling System

- Single head filling units available
- Adjustable bottle height, variable filling height and filling speed
- Operates on vacuum which is created when bottle is placed on filling nozzle, drawing a wine into the bottle
- No contact between wine and vacuum pump or mechanical components
- Single head unit can fill up to 250 bottles p/hr

## Semi Automatic Bottle Rinsers

- Fully stainless steel
- No bottle, no rinse
- Suits all bottle sizes and shapes
- Rinse water can be recirculated via microfiltration



## Benchmate Manual Labeller

- Hand wound operation
- Will apply both die cut and butt cut roll format self adhesive/ pressure sensitive labels to a range of cylindrical products
- Can apply single, or front and back labels
- Constructed of durable stainless steel and anodised aluminium
- Easy to set up and use



## Manual Pedestal Corker

- Rapid corker has 2 brass jaws with straight descending pin mechanism
- Ferrari corker has 4 brass jaws, 2 fixed and 2 moveable jaws - 3 piece unit with detachable lever and stand for efficient storage and transport
- Platina corker has 4 brass jaws, 2 fixed and 2 moveable jaws - available in one or three piece construction
- Mondial corker has 4 brass jaws, 2 fixed and 2 moveable jaws - flip latch below the jaws allows a half pushed in sparkling cork to be removed from the corker
- All units feature adjustable bottle height with an automatic bottle support locking device
- All units suit corks 20 to 32mm diameter X 28 to 50mm length



## Heat Shrink Capsule Sealer



- Models available: short heat coil unit, long heat coil unit, long heat coil unit with fan, bench mounted unit
- Body of unit fully constructed from stainless steel
- Long and short coil designs include support stand and long insulated handle for easy, safe use
- Bench unit includes safety grid to protect heating element plus a special chute designed for easy placement and removal of manually loaded bottles

## Automatic Bottling Lines

- Units available from capacities of 1,000 to 40,000 bottles p/hr
- Suitable for wine and sparkling wine
- Leading edge technologies and layout design provide optimum efficiency, to reduce labour and keep line stops to a minimum
- Monoblock units are available in a range of models
- Solid construction with stainless steel, ensuring long life and easier sterilisation
- Complete bottling lines
- Bottling lines are customised and tailored to customer requirements
- Consulting, installations, commissioning, training and maintenance available



## Capsuling Monobloc



Monoblock mechanical needle distributor equipped with 4+4 revolving head units, with thermal heads for PVC caps and rolling heads for poly laminate and aluminum caps. Fitted with a long-lasting magazine and a cap/cork checking device, it is equipped for use with a particular type of bottle. Designed to be highly user-friendly, it is easy to install and complete with safety shields.

**Maximum output:** 3500 bottles per hour with rolling heads.

**Maximum output:** 4500 bottles per hour with thermal heads.

## Rotary Labelling Machine

Automatic rotary labeler for attaching adhesive labels to bottles or cylindrical or square bottles of wine, consisting of:

- Capsule distributor complete with a turret with the opportunity to use 4 rolling heads + 1 thermal head
- 4 rolling heads, 4 thermal heads; a body labelling station
- 4 bottle-carrier plates; an inverter; an automatic speed control
- A label distributor with a stepping motor; end of roll photocell
- Overflow photocell at inlet and outlet

The rotary labeler is delivered ready for including in the bottling line and equipped for a given type of bottle. Made entirely of stainless steel, it is solid and strong, and based on an advanced technology, achieving a high output. Designed for maximum operator safety and ease of use, it is quick to adjust and complete with safety shields.





## Gravity Filling



Recommended for still, non-dense products such as for example still water, wine, alcoholic beverages (vodka, whiskey, brandy, etc), chemical products and generically any kind of flat non viscous liquids. In this case the opening of the filling valves is given by the neck finish of the containers, lifted by the mechanical plates of the filler.

Various models of filling valves are available within this category, specifically designed to cater for the filling level requirements, bottle shape, neck shape and product. Several optional features are available such as the “millimetric adjustment of the filling level” controlled directly from the user interface panel, air return outside the filling tank (to avoid the air from the bottles contaminating the product in the filler bowl), centralized level regulation and more.

## Counter Pressure Filling

Suitable for filling all kinds of carbonated and still products such as carbonated water, soft drinks, beer, etc., featuring various different types of filling valve designs, from the traditional mechanical counter-pressure valve which enables to carry out several phases such as pressurization, CO2 injection, multiple pre-evacuation, leveling and sniffling, to the most sophisticated electro-pneumatic valve where all those same functions are completely controlled and programmable from the operator panel, allowing the most up-to date technology and flexibility which is necessary to obtain high quality results and reduced risk of contamination.



## Depalletizers/Palletisers

- Low level and high level depalletising systems using both sweep off or pick & place technology
- Unscrambling systems for plastic containers
- Low level or high level layer palletisers with single or multiple infeed conveyors
- Semiautomatic Cartesian robot palletising systems with pallet on the ground for small production capacities
- Anthropomorphic Robot palletising systems offering the maximum flexibility, having up to six movement axes and therefore allowing for palletising individual or multiple boxes, up to handling the complete layer



## Box Making

- Systems up to 60,000 bottles per hour
- American Style carton or Wrap Around
- Hot Melt or Tape Sealing options
- Multiple bottle formats available



## Semi Automatic Labelling

Semiautomatic bench-mounted labelling machine with a labelling station. It can be used for: body labelling; front and back body labelling with back labels on the same roll. Suitable for all kinds of cylindrical bottle with a diameter in the range of 50mm to 120mm.

**Output:** 600 bottles per hour.



## Rinsers & Blowers

Various solutions are available depending on the specific requirements, such as double treatment rinsing, mobile nozzle rinsing, sterile air or inert gas blowing, rinsing with recycled and filtered products etc.



## Isobaric fillers for Sparkling Wines, Beers and Ciders

- Isobaric Tri-block lines capable of rinsing, filling and corking/capping or crown capping
- Built specifically to handle pressurised products
- It is possible to fill still wines under gravity by turning off the counter pressure feature

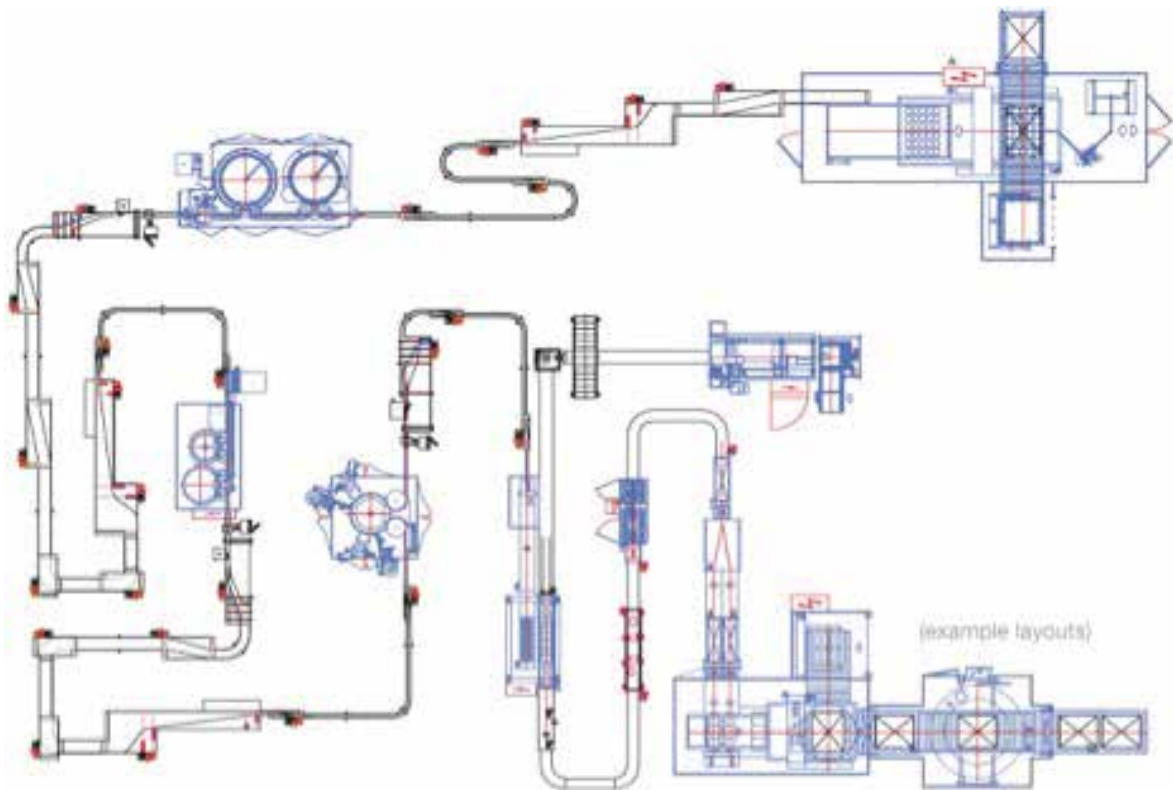

# 10. Cider & Perry

The background is a solid light orange color. It features three overlapping circles of varying shades of orange. The top-left circle is the largest and is a medium-dark orange. The middle-right circle is a darker orange and overlaps the bottom-right edge of the top-left circle. The bottom-left circle is a lighter orange and is filled with a pattern of small, evenly spaced dots.

# Cider

**Like the fresh energy in the wine industry, there's been a steady growth, a swelling of interest in "real" cider – cider that's hand-crafted, cider that reflects a place and a time, cider with finesse or a few rough edges – cider with a personality.**

Cider from apples, perry from pears, and cider from quince to name a few. The "new" makers of hard cider fall into many camps: some are orchardists; some make ciders very similar to wine; and some produce cider and market it like beer.

In Australia, the cider industry has grown by an average of about 20 per cent every year since 2008.

What we're seeing now is ciders that have a complexity of flavour, that can change each year in the same way as wine. We're seeing cider made in the Old World styles - or brown ciders, made using cider apples and borrowing from old European techniques; and we're seeing New World or white ciders, which use eating apples and are made more like a white wine. We're drinking bottle-conditioned cider, cider made by "keeving" (which involves separating nutrients from the juice and then fermenting slowly), sour fermented cider, and cider made a la methode champenoise (made just like champagne).

And there is a general agreement that certain cultivars produce a superior quality of cider to others, even though they may not give the highest yields nor be the easiest to grow - as in winemaking. Pinot Noir may be rated a "superior" red-wine grape than is Mataro, but just as in wine, an apple successful in one area may perform indifferently in another.

From a bushel, to a truck and trailer, we have the best equipment available anywhere to help you get started or keep growing.



# CIDER & PERRY

The right equipment for emptying through washing and mashing, pressing, filtering and settling and right up to pasteurisation, and filling - together with you we can create an optimal overall solution for fruit and vegetable processing.

- Stone fruit
- Apples
- Pear
- Quince
- Berries

## Equipment

- Milling and washing
- Destoning equipment
- Box tipping and bin tipping
- Pressing
- Pasteurising equipment
- Fillers

## Milling & Washing

- Elevator and auger models available. - up to 2000 kg/h
- Sorting grid
- Washing vessel
- Conveyor

**Optional:**  
Centrifugal mill with replaceable stainless grates of different grate capacity - from coarse to fine.



## Belt Press

- Juice yield up to 80%
- Belt press with pneumatic belt tensioner, auto belt control and high pressure belt clean. Optional brush cleaning system available for models with nominal ratings above 700kg/h
- From 300kg/h to 7000 kg/h



## Mobile Fruit Processing Technology

Virtually unrestricted mobility: the cidery comes to the fruit, and not the other way round. This results in great saving on material flow and transport and all related process steps and costs, and greatly improves energy, CO2 and ecological balance as a consequence.

- De-stoning, Washing and chopping
- Pressing
- Filter or centrifuge
- Settling tanks
- Pasteurization
- Filling for bottle or bag in box
- Juice trays
- Pumps
- Pull-out tables
- Customizable, and designed to be expanded and retrofitted as needs change



## Packing Press

- Juice yield 75%
- Movable juice basin
- Hydraulic power unit
- From 150kg/h to 600 kg/h



## Hydropress

- Utilises water pressure for pressing (sample and trial batches)
- Available in 20, 40, 80 and 160 litre cage capacities
- Fully stainless steel cage
- Includes pressure gauge and food grade rubber tube
- 20, 40 and 80 litre models stand upright on three legged stand
- 160 litre model is available on a tilt frame



# 11. Accessories & Fittings

The background features a solid yellow color with several overlapping circles. One large circle is in the upper left, another is in the middle right, and a third in the lower left contains a pattern of small white dots.





# ACCESSORIES & FITTINGS

## Fittings & Adaptors

Made to order, or stock items. Adapters, bends, BSM, BSP, Butterfly valves, camlocks, caps, clamps, DIN, Elbows, float valves, foot valves, gate valves, hose clamps, hose tails, non return valves, racking plates, reducers, sample valves, sight glass valves, sight glasses, spanners, sprayballs, sight glass spears, Tees....and all the shiny perfectly finished wine fittings you could ever need.



## Hoses

- Food grade PVC red helix reinforced suction hose available in diameters to suit 25, 38, 50, 63, 75 and 100mm. Tolerates temperatures of -5°C to 60°C
- Food grade PVC and steel wire helix reinforced suction hose available in diameters to suit 19, 25, 38, 50, 63, 75 and 100mm
- Tolerates temperatures of -5°C to 60°C
- Food grade PVC and polyester yarn reinforced delivery hose available in diameters of 12, 19, 25, 38 and 50mm. Tolerates temperatures of -5 °C to 60°C
- Food grade PVC delivery hose available in soft or heavy wall, in diameters from 3mm to 25mm. Tolerates temperatures of -10°C to 60°C
- Refrigeration hose suitable for the transfer of glycol at low and high temperature extremes
- All hoses are available per metre or by the roll



## Nitrogen Generators

The Nitrogen Generators CEP allow in a simple; safe and extremely economical production of Nitrogen Supply (E 941 Meets Eiga according to the Food Standards 2000/63/EC 95/2/UE and 178/2002/UE).

The machine uses the different time of release of oxygen and nitrogen by a series of tanks containing active carbon working alternately ensuring a continuous production of Nitrogen.

Our generators are optimized to obtain the best performance by a careful design of the fluid dynamics and management software.

Nitrogen is produced from the decomposition of the atmospheric air pressurized by a screw compressor, dried and purified.

The machines are supplied standard with 99.5% purity Nitrogen Nm<sup>3</sup> / H and you can change the concentration of the nitrogen product.

All generators are equipped as standard with oxygen analyzer integrated to assess the purity of nitrogen in real time.

The machine is complete with electric 220Volt 50Hz. Single phase with Touch-Screen display.





**Vitis &  
Winemakers**

[www.vitiswinemakers.com](http://www.vitiswinemakers.com)